



# GEN-2023-GR1

## GENERATOR REPLACEMENT STUDY

By Aneden Consulting and SPP Generator Interconnection

Published on 05/03/2024

# REVISION HISTORY

---

DATE OR VERSION NUMBER	AUTHOR	CHANGE DESCRIPTION	COMMENTS
04/17/2024	Aneden Consulting & SPP Staff	Original Version	

# CONTENTS

---

REVISION HISTORY.....	1
LIST OF TABLES.....	2
LIST OF FIGURES.....	2
APPENDICES.....	2
EXECUTIVE SUMMARY .....	3
SCOPE OF STUDY .....	5
Reliability Assessment Study .....	6
Replacement Impact Study .....	6
Steady State Analysis.....	6
Stability and Short Circuit Analyses .....	6
Reactive Power Analysis .....	7
Study Limitations.....	7
PROJECT AND REPLACEMENT REQUEST .....	8
RELIABILITY ASSESSMENT STUDY .....	11
REPLACEMENT IMPACT STUDY .....	12
Existing Vs. Replacement Comparison.....	12
Stability Model Parameters Comparision .....	12
Equivalent Impedance Comparison Calculation.....	12
Short-Circuit Analysis .....	13
Methodology.....	13
Results.....	13
Dynamic Stability Analysis .....	15
Methodology and Criteria .....	15
Fault Definitions.....	16
Results.....	25
Installed Capacity Exceeds GIA Capacity.....	29
Necessary Interconnection Facilities.....	29
RESULTS.....	30
Reliability Assessment Study .....	30

Replacement Impact Study .....	30
Next Steps.....	30

## LIST OF TABLES

---

Table 1: EGF and RGF Configuration Details.....	10
Table 2: GEN-2023-GR1 Short-Circuit Parameters* .....	13
Table 3: POI Short-Circuit Results.....	14
Table 4: 25SP Short-Circuit Results .....	14
Table 5: Fault Definitions.....	17
Table 6: Stability Analysis Results .....	26
Table 7: Necessary Interconnection Facilities.....	29

## LIST OF FIGURES

---

Figure 1: Existing Generation Single Line Diagram (EGF Configuration)*.....	9
Figure 2: GEN-2023-GR1 Single Line Diagram (RGF Configuration) .....	9

## APPENDICES

---

APPENDIX A: GEN-2023-GR1 Generator Dynamic Model

APPENDIX B: Short Circuit Results

APPENDIX C: Dynamic Stability Results with Existing Base Case Issues & Simulation Plots

# EXECUTIVE SUMMARY

---

Pursuant to the Southwest Power Pool (SPP) Open Access Transmission Tariff (SPP tariff) Attachment V section 3.9 and SPP Business Practice 7800, Interconnection Customers can submit replacement requests for its Existing Generating Facilities. The Interconnection Customer of an Existing Generating Facility (EGF) with a Point of Interconnection (POI) at the Anadarko 69 kV Substation requested to be studied in the SPP Generator Replacement process.

GEN-2023-GR1, the Replacement Generating Facility (RGF), will connect to the existing POI, the Anadarko 69 kV Substation in the Western Farmers Electric Cooperative (WFEC) area.

The EGF has 98.822 MW of available replacement capacity, based on the nameplate of the generating facility provided by the Interconnection Customer. This study has been requested to evaluate the impact of the RGF, consisting of 2 x GE LM6000 51.309 MVA synchronous gas-fired units with a total assumed dispatch of 98.972/97.1 MW Summer/Winter. This generating capability for the RGF exceeds its requested Interconnection Service amount of a summer capacity of 97.488 MW and winter capacity of 95.644 MW at the POI. As a result, the customer must install monitoring and control equipment as needed to ensure that the amount of power injected at the POI does not exceed the Interconnection Service amount. To operate above these amounts, a new Interconnection Request would need to be submitted.

The Generator Replacement Process consists of two parts: a Reliability Assessment Study and a Replacement Impact Study. The Reliability Assessment Study identifies any system impacts after the removal of the EGF from service and before the commission date of the RGF with proposed system adjustments to mitigate any issues. The Replacement Impact Study evaluates whether the RGF is a Material Modification.

## **Reliability Assessment Study**

Because the EGF was considered retired prior to the Generating Facility Replacement, the performance of the Transmission System with the EGF ceasing commercial operations is the status quo. SPP determined that for the Reliability Assessment Study, no further analysis for the time between removing from service of the EGF and the commission of the RGF is necessary, and no mitigations are applicable.

## **Replacement Impact Study**

Aneden Consulting (Aneden) was retained by SPP to perform the Replacement Impact Study (Impact Study) for GEN-2023-GR1.

SPP determined that steady-state analysis was not required as the EGF is a Legacy unit and as such was not subject to a DISIS steady-state analysis. Since the RGF is a synchronous generator, a reactive power analysis was not required.

However, SPP determined that short circuit and dynamic stability analyses were required as the dynamic model for the EGF and RGF are different (GENCLS and GENROU [EGF] and GENTPJ1 [RGF]). The scope of this Impact Study included short circuit analysis and dynamic stability analysis.

The results of the Impact Study showed that the requested replacement did not have a material adverse impact on the SPP transmission system. The requested generator replacement of the EGF with GEN-2023-GR1 was determined **not a Material Modification**.

It is likely that the customer may be required to reduce its generation output in real-time, also known as curtailment, under certain system conditions to allow system operators to maintain the reliability of the transmission network.

Nothing in this study should be construed as a guarantee of transmission service or delivery rights. Transfer of an existing resource designation from the EGF to the RGF can be achieved by submitting a transfer of designation request pursuant to Section 30.2.1 of the SPP tariff. If the customer would like to obtain new deliverability to final customers, a separate request for transmission service must be requested on SPP's OASIS by the customer.

# SCOPE OF STUDY

---

Pursuant to SPP tariff Attachment V section 3.9 and SPP Business Practice 7800, Interconnection Customers can submit replacement requests for its Existing Generating Facilities. A Generator Replacement Impact Study is an interconnection study performed to evaluate the impacts of replacing existing generation with new generation. Two analyses covering different time frames are evaluated:

- Reliability Assessment Study – study performed to evaluate the performance of the Transmission System for the period between the date that the Existing Generating Facility (EGF) ceases commercial operations and the Commercial Operation Date (COD) of the Replacement Generating Facility (RGF).
- Replacement Impact Study – study performed to evaluate if the RGF has a material adverse impact on the SPP Transmission System.

For any impacts to the system identified in the Reliability Assessment Study, non-transmission solutions such as redispatch, remedial action schemes, or reactive setting adjustments will be identified to mitigate issues originating after the removal of the EGF from service and before the commission of the RGF.

If the Replacement Impact Study identifies any materially adverse impact from operating the RGF when compared to the EGF, such impacts shall be deemed a Material Modification.

## RELIABILITY ASSESSMENT STUDY

The Reliability Assessment Study, for the time period between the date that the EGF ceases commercial operations and the Commercial Operation Date of the RGF, evaluates the performance of the Transmission System.

This study compares the conditions on the Transmission System that would exist if the EGF is taken offline to the conditions on the Transmission System as they exist when the EGF is online. The EGF would be responsible for mitigating any reliability violation identified in the study and may not cease operations until all mitigations are implemented or are in service.

Because the EGF was considered retired prior to the Generating Facility Replacement and was out-of-service in the latest planning assessment models, the performance of the Transmission System with the EGF ceasing commercial operations is the status quo. SPP determined that for the Reliability Assessment Study, no further analysis for the time between removing from service of the EGF and the commission of the RGF is necessary, and no mitigations are applicable.

## REPLACEMENT IMPACT STUDY

Aneden Consulting (Aneden) was retained by SPP to perform the Replacement Impact Study (Impact Study) for GEN-2023-GR1. All analyses were performed using Siemens PTI PSS/E version 34 software.

## STEADY STATE ANALYSIS

To determine whether steady-state analysis is required, SPP evaluates if all required reliability conditions were previously studied. This is done by comparing the current DISIS steady-state requirements versus the steady-state analysis previously performed on the EGF. SPP determined that since the EGF was a Legacy unit and was not subject to a DISIS steady-state analysis, no steady-state analysis for the RGF is required.

## STABILITY AND SHORT CIRCUIT ANALYSES

To determine whether stability and short circuit analyses are required, SPP evaluates the difference between the stability models and corresponding parameters and, if needed, the collector system impedance between the existing configuration and the requested replacement. Dynamic stability analysis and short circuit analysis shall be performed if the differences listed above may result in a significant impact on the most recently performed DISIS stability analysis.



## REACTIVE POWER ANALYSIS

The reactive power analysis determines the capacitive effect at the POI caused by the project's collector system and transmission line's capacitance. A shunt reactor size is determined in order to offset the capacitive effect and maintain zero (0) MVar flow at the POI while the project's generators and capacitors (if any) are offline. A reactive power analysis was not performed on the requested replacement configuration as it is a synchronous generator resource.

## STUDY LIMITATIONS

The assessments and conclusions provided in this report are based on assumptions and information provided to SPP/Aneaden by others. While the assumptions and information provided may be appropriate for the purposes of this report, SPP/Aneaden does not guarantee that those conditions assumed will occur. In addition, SPP/Aneaden did not independently verify the accuracy or completeness of the information provided. As such, the conclusions and results presented in this report may vary depending on the extent to which actual future conditions differ from the assumptions made or information used herein.

# PROJECT AND REPLACEMENT REQUEST

---

The GEN-2023-GR1 Interconnection Customer has requested a replacement to its EGF, a synchronous gas-fired generating facility with a POI at the Anadarko 69 kV Substation and a requested retirement date of November 30, 2025. The Interconnection Service available for replacement is 98.822 MW, based on the nameplate of the generating facility provided by the Interconnection Customer. Of the Interconnection Service available, the RGF Interconnection Customer has requested 97.488/95.644 MW Summer/Winter of Energy Resource Interconnection Service (ERIS). The requested RGF is a synchronous gas-fired generation plant consisting of 2 x GE LM6000 51.309 MVA units with a total assumed dispatch of 98.972/97.1 MW Summer/Winter. This generating capability for the RGF exceeds its requested Interconnection Service amount of a summer capacity of 97.488 MW and winter capacity of 95.644 MW at the POI. As a result, the customer must install monitoring and control equipment as needed to ensure that the amount of power injected at the POI does not exceed the Interconnection Service amount. To operate above these amounts, a new Interconnection Request would need to be submitted.

The RGF has a planned commercial operation date of December 1, 2025. The EGF predated the SPP GI queue and does not have an SPP Generation Interconnection Agreement (GIA).

The POI of the EGF and RGF is at the Anadarko 69 kV Substation in the Western Farmers Electric Cooperative (WFEC) area, and the EGF and RGF are not expected to be operational simultaneously. Figure 1 and Figure 2 show the steady state model single-line diagram for the EGF and RGF configurations, respectively. Table 1 details the existing and replacement configurations for GEN-2023-GR1.

Because the Interconnection Customer requested less Interconnection Service for the RGF than was made available by the EGF, the remaining capacity is assumed unused as part of this replacement request. Should the Interconnection Customer choose to proceed with this replacement, the remaining unused capacity would be subject to a separate replacement request such that the total replacement capacity does not exceed this amount and other requirements from SPP tariff Attachment V section 3.9 are met.

**Figure 1: Existing Generation Single Line Diagram (EGF Configuration)\***

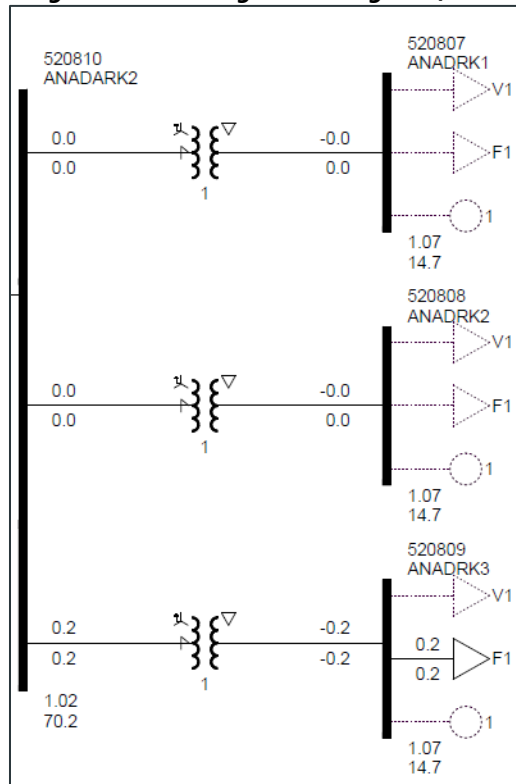

\*based on the DISIS-2018-002/2019-001 25SP stability models

**Figure 2: GEN-2023-GR1 Single Line Diagram (RGF Configuration)**

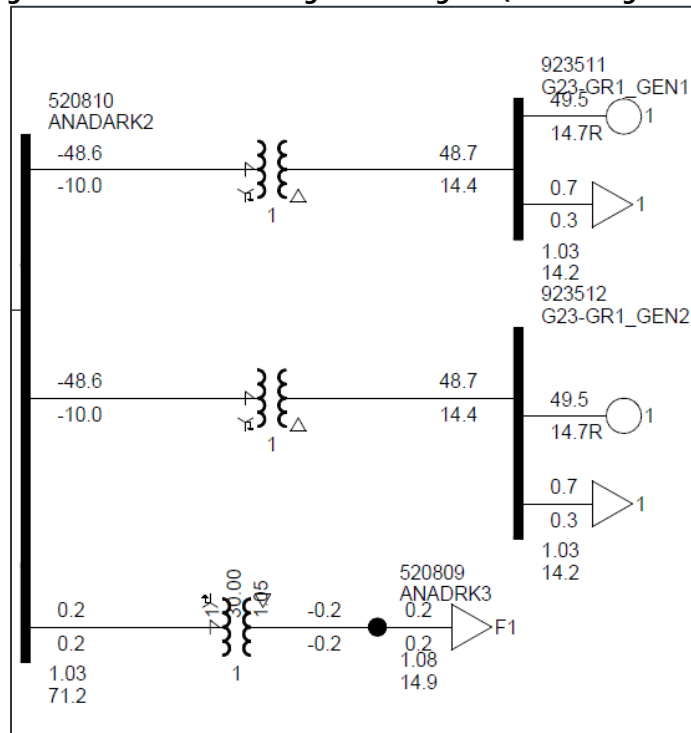

**Table 1: EGF and RGF Configuration Details**

Facility	Existing Generator Facility Configuration			Replacement Generator Facility Configuration	
Point of Interconnection	Anadarko 69 kV Substation (520810)			Anadarko 69 kV Substation (520810)	
Configuration/Capacity	3 Synchronous Gas-Fired Units totaling 98.822 MW Capacity (limited by GSU)			2 x GE LM6000 51.309 MVA Gas Turbines = 102.618 MVA [98.972/97.1 MW Summer/Winter dispatch] POI limited to 97.488/95.644 MW Summer/Winter	
Generator Step Up Transformer <sup>1</sup>	X = 7.7%, R = 0.0%, Voltage = 13.8/69 kV, Winding MVA = 20 MVA, Rating MVA = 20 MVA	X = 7.7%, R = 0.0%, Voltage = 13.8/69 kV, Winding MVA = 20 MVA, Rating MVA = 20 MVA	X = 10.37%, R = 0.0%, Voltage = 13.8/69 kV, Winding MVA = 60 MVA, Rating MVA = 60 MVA	X = 7.997%, R = 0.229%, Voltage = 13.8/69 kV (Delta/Wye), Fixed Taps Available = 5 Taps, ±5% Winding MVA = 45 MVA, Rating MVA = 75 MVA	X = 7.997%, R = 0.229%, Voltage = 13.8/69 kV (Delta/Wye), Fixed Taps Available = 5 Taps, ±5% Winding MVA = 45 MVA, Rating MVA = 75 MVA
Auxiliary Load	0.12 MW + 0.02 MVAR on 13.8 kV bus	0.11 MW + 0.02 MVAR on 13.8 kV bus	0.23 MW + 0.17 MVAR on 13.8 kV bus	0.742/0.728 MW [Summer/Winter] + 0.3 MVAR on 13.8 kV bus	0.742/0.728 MW [Summer/Winter] + 0.3 MVAR on 13.8 kV bus
	1.05 MW + 0.53 MVAR on 13.8 kV bus	0.99 MW + 0.47 MVAR on 13.8 kV bus	2.07 MW + 1.53 MVAR on 13.8 kV bus	Existing Unit 3 Load Still Online: 0.23 MW + 0.17 MVAR on 13.8 kV bus	
Generator Dynamic Model <sup>2</sup> & Power Factor	GENCLS <sup>2</sup>	GENCLS <sup>2</sup>	GENROU <sup>2</sup>	1 x GE LM6000 Gas Turbine 51.309 MVA (GENTPJ1) <sup>2</sup>	1 x GE LM6000 Gas Turbine 51.309 MVA (GENTPJ1) <sup>2</sup>
	Leading: 0	Leading: 0	Leading: 0.86	Leading: 0.95	Leading: 0.95
	Lagging: 0	Lagging: 0	Lagging: 0.99	Lagging: 0.95	Lagging: 0.95
1) X and R based on Winding MVA, 2) DYR stability model name					

# RELIABILITY ASSESSMENT STUDY

---

The Reliability Assessment Study, for the time period between the date that the EGF ceases commercial operations and the Commercial Operation Date of the RGF, evaluates the performance of the Transmission System.

This study compares the conditions on the Transmission System that would exist if the EGF is taken offline to the conditions on the Transmission System as they exist when the EGF is online. The EGF would be responsible for mitigating any reliability violation identified in the study and may not cease operations until all mitigations are implemented or are in service.

Because the EGF was considered retired prior to the Generating Facility Replacement, the performance of the Transmission System with the EGF ceasing commercial operations is the status quo. SPP determined that for the Reliability Assessment Study, no further analysis for the time between removing from service of the EGF and the commission of the RGF is necessary, and no mitigations are applicable.

# REPLACEMENT IMPACT STUDY

---

Aneden was retained by SPP to perform the Replacement Impact Study (Impact Study) for GEN-2023-GR1.

## EXISTING VS. REPLACEMENT COMPARISON

To determine which analyses are required for the Impact Study, the differences between the existing configuration and the requested replacement were evaluated. SPP performed this comparison and the resulting analyses using a set of modified study models developed based on the replacement request data and the DISIS-2018-002/2019-001 study models.

## STABILITY MODEL PARAMETERS COMPARISON

Because the dynamic model for the EGF and RGF are different (GENCLS and GENROU [EGF] and GENTPJ1 [RGF]), SPP determined short-circuit and dynamic stability analyses were required. This is because the short-circuit contribution and stability responses of the existing configuration and the requested replacement's configuration may differ. The generator dynamic model for the RGF can be found in Appendix A.

As short-circuit and dynamic stability analyses were required, a stability model parameters comparison was not needed for the determination of the scope of the study.

## EQUIVALENT IMPEDANCE COMPARISON CALCULATION

As the stability model change determined that short circuit and dynamic stability analyses were required, an equivalent impedance comparison was not needed for the determination of the scope of the study.

## SHORT-CIRCUIT ANALYSIS

Aneden performed a short circuit study using the 25SP model to determine the maximum fault current requiring interruption by protective equipment with the RGF online for each bus in the relevant subsystem, and the amount of increase in maximum fault current due to the addition of the RGF. The detailed results of the short circuit analysis are provided in Appendix B.

## METHODOLOGY

The short-circuit analysis included applying a three-phase fault on buses up to five levels away from the 69 kV POI bus. The PSS/E “Automatic Sequence Fault Calculation (ASCC)” fault analysis module was used to calculate the fault current levels in the transmission system with and without the GEN-2023-GR1 RGF online.

SPP created a short circuit model using the 25SP stability study model by adjusting the GEN-2023-GR1 short-circuit parameters consistent with the replacement data. The adjusted parameters are shown in Table 2 below.

**Table 2: GEN-2023-GR1 Short-Circuit Parameters\***

Parameter	Value by Generator Bus#	Value by Generator Bus#
	923511	923512
Machine MVA Base	51.31	51.31
R (pu)	0.005	0.005
X'' (pu)	0.144	0.144

\*pu values based on Machine MVA Base

## RESULTS

The results of the short circuit analysis for the 25SP model are summarized in Table 3 and Table 4. The GEN-2023-GR1 POI bus (Anadarko 69 kV) fault current magnitude is provided in Table 3 showing a fault current of 18.12 kA with the RGF online. The addition of the RGF increased the POI bus fault current by 3.64 kA. Table 4 shows the maximum fault current magnitudes and fault current increases with the RGF project online.

The maximum fault current calculated within 5 buses of the POI was 38.6 kA for the 25SP model. The maximum contribution to three-phase fault currents due to the addition of the RGF was about 25.2% and 3.64 kA at the 69 kV POI bus.

**Table 3: POI Short-Circuit Results**

Case	EGF and RGF-OFF Current (kA)	RGF-ON Current (kA)	kA Change	%Change
25SP	14.47	18.12	3.64	25.2%

**Table 4: 25SP Short-Circuit Results**

Voltage (kV)	Max. Current (kA)	Max kA Change	Max %Change
69	18.12	3.64	25.2%
138	38.60	1.21	3.2%
345	34.11	0.11	0.6%
<b>Max</b>	<b>38.60</b>	<b>3.64</b>	<b>25.2%</b>



## DYNAMIC STABILITY ANALYSIS

Aneden performed a dynamic stability analysis to identify the impact of the GEN-2023-GR1 project. The analysis was performed according to SPP's Disturbance Performance Requirements<sup>1</sup>. The replacement details are described in the Project and Replacement Request section and the dynamic modeling data is provided in Appendix A. The existing base case issues and simulation plots can be found in Appendix C.

## METHODOLOGY AND CRITERIA

The dynamic stability analysis was performed using models developed with the requested RGF configuration of 2 x GE LM6000 51.309 MVA synchronous gas-fired units (GENTPJ1) with a total assumed dispatch of 98.972/97.1 MW Summer/Winter. This stability analysis was performed using PTI's PSS/E version 34.8.0 software.

The RGF project details were used to create modified stability models for this impact study based on the DISIS-2018-002/2019-001 stability study models:

- 2025 Summer Peak (25SP)
- 2025 Winter Peak (25WP)

The dynamic model data for the GEN-2023-GR1 project is provided in Appendix A. The modified power flow models and associated dynamics database were initialized (no-fault test) to confirm that there were no errors in the initial conditions of the system and the dynamic data.

The following system adjustments were made to address existing base case issues that are not attributed to the replacement request:

- The frequency protective relays at buses 763002, 5879581, 534033, 587793, & 587773 were disabled after observing the generators tripping during initial three phase fault simulations. This frequency tripping issue is a known PSS/E limitation when calculating bus frequency as it relates to non-conventional type devices.
- The voltage protective relays at buses 587793, 920001, 920002, 920003, 920004, 520522, & 516022 were disabled to avoid generator tripping due to an instantaneous over voltage spike after fault clearing.
- The fault simulation file acceleration factor was reduced as needed to resolve stability simulation crashes.

---

<sup>1</sup> [SPP Disturbance Performance Requirements:](https://www.spp.org/documents/28859/spp%20disturbance%20performance%20requirements%20(twg%20approved).pdf)

[https://www.spp.org/documents/28859/spp%20disturbance%20performance%20requirements%20\(twg%20approved\).pdf](https://www.spp.org/documents/28859/spp%20disturbance%20performance%20requirements%20(twg%20approved).pdf)

- The WTDTA1 models were disabled at buses 534023, 532957, 579483, 579486, 760003, 760006, 532712, 532713, 532714, 532715, 539845, 539846, 539847, 539848, 539852, 539853, 543654, 588363, 588983, 588984, 589203, 589204, 589243, 760581, 760584, 760749, & 760752 to resolve stability simulation crashes.

During the fault simulations, the active power (PELEC), reactive power (QELEC), and terminal voltage (ETERM) were monitored for the EGF and SGF and other current and prior queued projects in Group 4. In addition, voltages of five (5) buses away from the POI of the RGF were monitored and plotted. The machine rotor angle for synchronous machines and speed for asynchronous machines within the study areas including 327 (EES-EAI), 330 (AECI), 351 (EES), 356 (AMMO), 502 (CLEC), 515 (SWPA), 520 (AEPW), 523 (GRDA), 524 (OKGE), 525 (WFEC), 526 (SPS), 527 (OMPA), 534 (SUNC), 536 (WERE), 544 (EMDE), and 546 (SPRM) were monitored. The voltages of all 100 kV and above buses within the study area were monitored as well.

## FAULT DEFINITIONS

Aneden developed fault events as required to study the RGF. The new set of faults was simulated using the modified study models. The fault events included three-phase faults and single-line-to-ground stuck breaker faults. Single-line-to-ground faults are approximated by applying a fault impedance to bring the faulted bus positive sequence voltage to 0.6 pu. The simulated faults are listed and described in Table 5. These contingencies were applied to the modified 25SP and 25WP models.

**Table 5: Fault Definitions**

Fault ID	Planning Event	Fault Descriptions
FLT9001-3PH	P1	3 phase fault on the ANADARK4 (520814) to GRACMNT4 (515802) 138kV line CKT 1, near ANADARK4. a. Apply fault at the ANADARK4 138 kV bus. b. Clear fault after 7 cycles by tripping the faulted line. c. Wait 20 cycles, and then re-close the line in (b) back into the fault. d. Leave fault on for 7 cycles, then trip the line in (b) and remove fault.
FLT9002-3PH	P1	3 phase fault on the ANADARK4 (520814) to S.W.S-4 (511477) 138kV line CKT 1, near ANADARK4. a. Apply fault at the ANADARK4 138 kV bus. b. Clear fault after 7 cycles by tripping the faulted line. c. Wait 20 cycles, and then re-close the line in (b) back into the fault. d. Leave fault on for 7 cycles, then trip the line in (b) and remove fault.
FLT9003-3PH	P1	3 phase fault on the ANADARK4 (520814) to CHERRYRD4 (521129) 138kV line CKT 1, near ANADARK4. a. Apply fault at the ANADARK4 138 kV bus. b. Clear fault after 7 cycles by tripping the faulted line. c. Wait 20 cycles, and then re-close the line in (b) back into the fault. d. Leave fault on for 7 cycles, then trip the line in (b) and remove fault.
FLT9004-3PH	P1	3 phase fault on the ANADARK4 (520814) to POCASET4 (521031) 138kV line CKT 1, near ANADARK4. a. Apply fault at the ANADARK4 138 kV bus. b. Clear fault after 7 cycles by tripping the faulted line. c. Wait 20 cycles, and then re-close the line in (b) back into the fault. d. Leave fault on for 7 cycles, then trip the line in (b) and remove fault.
FLT9005-3PH	P1	3 phase fault on the ANADARK4 (520814) to CLVLDSW4 (520508) 138kV line CKT 1, near ANADARK4. a. Apply fault at the ANADARK4 138 kV bus. b. Clear fault after 7 cycles by tripping the faulted line. c. Wait 20 cycles, and then re-close the line in (b) back into the fault. d. Leave fault on for 7 cycles, then trip the line in (b) and remove fault.
FLT9006-3PH	P1	3 phase fault on the ANADARK4 (520814) to GEROGIA4 (520923) 138kV line CKT 1, near ANADARK4. a. Apply fault at the ANADARK4 138 kV bus. b. Clear fault after 7 cycles by tripping the faulted line. c. Wait 20 cycles, and then re-close the line in (b) back into the fault. d. Leave fault on for 7 cycles, then trip the line in (b) and remove fault.
FLT9007-3PH	P1	3 phase fault on the ANADARK4 (520814) to SEQUOYAHJ4 (520422) 138kV line CKT 1, near ANADARK4. a. Apply fault at the ANADARK4 138 kV bus. b. Clear fault after 7 cycles by tripping the faulted line. c. Wait 20 cycles, and then re-close the line in (b) back into the fault. d. Leave fault on for 7 cycles, then trip the line in (b) and remove fault.
FLT9008-3PH	P1	3 phase fault on the ANADARKO 138 kV (520814) /69 kV (520810) /13.8kV (521181) transformer CKT 1, near ANADARK4 138kV. a. Apply fault at the ANADARK4 138 kV (520814) bus. b. Clear fault after 7 cycles by tripping the faulted line.
FLT9009-3PH	P1	3 phase fault on the ANADARK 138 kV (520814) /13.8 kV (520811) transformer CKT 1, near ANADARK4 138kV. a. Apply fault at the ANADARK4 138 kV (520814) bus. b. Clear fault after 7 cycles by tripping the faulted line. Trip generator on bus ANADRK4 (520811)
FLT9010-3PH	P1	3 phase fault on the ORME 138 kV (520814) /13.8 kV (521110) transformer CKT 1, near ANADARK4 138kV. a. Apply fault at the ANADARK4 138 kV (520814) bus. b. Clear fault after 7 cycles by tripping the faulted line. Trip generator on bus ORME1 (521110)

Table 5 Continued

Fault ID	Planning Event	Fault Descriptions
FLT9011-3PH	P1	3 phase fault on the CHERRYRD4 (521129) to BCV SW4 (520513) 138kV line CKT 1, near CHERRYRD4. a. Apply fault at the CHERRYRD4 138 kV bus. b. Clear fault after 7 cycles by tripping the faulted line. Trip generator on bus BCV WTG (520521) c. Wait 20 cycles, and then re-close the line in (b) back into the fault. d. Leave fault on for 7 cycles, then trip the line in (b) and remove fault.
FLT9012-3PH	P1	3 phase fault on the CHERRYRD4 (521129) to PARADSE4 (521024) 138kV line CKT 1, near CHERRYRD4. a. Apply fault at the CHERRYRD4 138 kV bus. b. Clear fault after 7 cycles by tripping the faulted line. c. Wait 20 cycles, and then re-close the line in (b) back into the fault. d. Leave fault on for 7 cycles, then trip the line in (b) and remove fault.
FLT9013-3PH	P1	3 phase fault on the PARADSE4 (521024) to MDCPRK4 (520404) 138kV line CKT 1, near PARADSE4. a. Apply fault at the PARADSE4 138 kV bus. b. Clear fault after 7 cycles by tripping the faulted line. c. Wait 20 cycles, and then re-close the line in (b) back into the fault. d. Leave fault on for 7 cycles, then trip the line in (b) and remove fault.
FLT9014-3PH	P1	3 phase fault on the POCASET4 (521031) to TUTLETP4 (521072) 138kV line CKT 1, near POCASET4. a. Apply fault at the POCASET4 138 kV bus. b. Clear fault after 7 cycles by tripping the faulted line. c. Wait 20 cycles, and then re-close the line in (b) back into the fault. d. Leave fault on for 7 cycles, then trip the line in (b) and remove fault.
FLT9015-3PH	P1	3 phase fault on the CLVLDSW4 (520508) to AMBERTP4 (520530) 138kV line CKT 1, near CLVLDSW4. a. Apply fault at the CLVLDSW4 138 kV bus. b. Clear fault after 7 cycles by tripping the faulted line. c. Wait 20 cycles, and then re-close the line in (b) back into the fault. d. Leave fault on for 7 cycles, then trip the line in (b) and remove fault.
FLT9016-3PH	P1	3 phase fault on the CLVLDSW4 (520508) to COGAR 4 (520859) 138kV line CKT 1, near CLVLDSW4. a. Apply fault at the CLVLDSW4 138 kV bus. b. Clear fault after 7 cycles by tripping the faulted line. c. Wait 20 cycles, and then re-close the line in (b) back into the fault. d. Leave fault on for 7 cycles, then trip the line in (b) and remove fault.
FLT9017-3PH	P1	3 phase fault on the TUTLETP4 (521072) to TUTTLE 4 (520496) 138kV line CKT 1, near TUTLETP4. a. Apply fault at the TUTLETP4 138 kV bus. b. Clear fault after 7 cycles by tripping the faulted line. c. Wait 20 cycles, and then re-close the line in (b) back into the fault. d. Leave fault on for 7 cycles, then trip the line in (b) and remove fault.
FLT9018-3PH	P1	3 phase fault on the TUTLETP4 (521072) to BRIDGCR4 (520501) 138kV line CKT 1, near TUTLETP4. a. Apply fault at the TUTLETP4 138 kV bus. b. Clear fault after 7 cycles by tripping the faulted line. c. Wait 20 cycles, and then re-close the line in (b) back into the fault. d. Leave fault on for 7 cycles, then trip the line in (b) and remove fault.

**Table 5 Continued**

Fault ID	Planning Event	Fault Descriptions
FLT9019-3PH	P1	3 phase fault on the AMBERTP4 (520530) to BLANCHD4 (520828) 138kV line CKT 1, near AMBERTP4. a. Apply fault at the AMBERTP4 138 kV bus. b. Clear fault after 7 cycles by tripping the faulted line. c. Wait 20 cycles, and then re-close the line in (b) back into the fault. d. Leave fault on for 7 cycles, then trip the line in (b) and remove fault.
FLT9020-3PH	P1	3 phase fault on the AMBERTP4 (520530) to AMBER 4 (520531) 138kV line CKT 1, near AMBERTP4. a. Apply fault at the AMBERTP4 138 kV bus. b. Clear fault after 7 cycles by tripping the faulted line. c. Wait 20 cycles, and then re-close the line in (b) back into the fault. d. Leave fault on for 7 cycles, then trip the line in (b) and remove fault.
FLT9021-3PH	P1	3 phase fault on the COGAR 4 (520859) to REDCNTP4 (520552) 138kV line CKT 1, near COGAR 4. a. Apply fault at the COGAR 4 138 kV bus. b. Clear fault after 7 cycles by tripping the faulted line. c. Wait 20 cycles, and then re-close the line in (b) back into the fault. d. Leave fault on for 7 cycles, then trip the line in (b) and remove fault.
FLT9022-3PH	P1	3 phase fault on the ANADARK2 (520810) to HARPER2 (520440) 69kV line CKT 1, near ANADARK2. a. Apply fault at the ANADARK2 69 kV bus. b. Clear fault after 7 cycles by tripping the faulted line. c. Wait 20 cycles, and then re-close the line in (b) back into the fault. d. Leave fault on for 7 cycles, then trip the line in (b) and remove fault.
FLT9023-3PH	P1	3 phase fault on the ANADARK2 (520810) to CADDO 2 (520838) 69kV line CKT 1, near ANADARK2. a. Apply fault at the ANADARK2 69 kV bus. b. Clear fault after 7 cycles by tripping the faulted line. c. Wait 20 cycles, and then re-close the line in (b) back into the fault. d. Leave fault on for 7 cycles, then trip the line in (b) and remove fault.
FLT9024-3PH	P1	3 phase fault on the HARPER2 (520440) to CYRIL 2 (520870) 69kV line CKT 1, near HARPER2. a. Apply fault at the HARPER2 69 kV bus. b. Clear fault after 7 cycles by tripping the faulted line. c. Wait 20 cycles, and then re-close the line in (b) back into the fault. d. Leave fault on for 7 cycles, then trip the line in (b) and remove fault.
FLT9025-3PH	P1	3 phase fault on the GRACMNT4 138 kV (515802) /345 kV (515800) /13.8kV (515801) transformer CKT 1, near GRACMNT4 138kV. a. Apply fault at the GRACMNT4 138 kV (515802) bus. b. Clear fault after 7 cycles by tripping the faulted line.
FLT9026-3PH	P1	3 phase fault on the GRACMNT4 (515802) to WASHITA4 (521089) 138kV line CKT 1, near GRACMNT4. a. Apply fault at the GRACMNT4 138 kV bus. b. Clear fault after 7 cycles by tripping the faulted line. c. Wait 20 cycles, and then re-close the line in (b) back into the fault. d. Leave fault on for 7 cycles, then trip the line in (b) and remove fault.
FLT9027-3PH	P1	3 phase fault on the S.W.S-4 (511477) to WASHITA4 (521089) 138kV line CKT 1, near S.W.S-4. a. Apply fault at the S.W.S-4 138 kV bus. b. Clear fault after 7 cycles by tripping the faulted line. c. Wait 20 cycles, and then re-close the line in (b) back into the fault. d. Leave fault on for 7 cycles, then trip the line in (b) and remove fault.
FLT9028-3PH	P1	3 phase fault on the S.W.S-4 (511477) to ELSWORTH 4 (511563) 138kV line CKT 1, near S.W.S-4. a. Apply fault at the S.W.S-4 138 kV bus. b. Clear fault after 7 cycles by tripping the faulted line. c. Wait 20 cycles, and then re-close the line in (b) back into the fault. d. Leave fault on for 7 cycles, then trip the line in (b) and remove fault.
FLT9029-3PH	P1	3 phase fault on the S.W.S-4 (511477) to CARNEG-4 (511445) 138kV line CKT 1, near S.W.S-4. a. Apply fault at the S.W.S-4 138 kV bus. b. Clear fault after 7 cycles by tripping the faulted line. c. Wait 20 cycles, and then re-close the line in (b) back into the fault. d. Leave fault on for 7 cycles, then trip the line in (b) and remove fault.

**Table 5 Continued**

Fault ID	Planning Event	Fault Descriptions
FLT9030-3PH	P1	3 phase fault on the S.W.S-4 (511477) to VERDEN 4 (511421) 138kV line CKT 1, near S.W.S-4. a. Apply fault at the S.W.S-4 138 kV bus. b. Clear fault after 7 cycles by tripping the faulted line. c. Wait 20 cycles, and then re-close the line in (b) back into the fault. d. Leave fault on for 7 cycles, then trip the line in (b) and remove fault.
FLT9031-3PH	P1	3 phase fault on the S.W.S-4 (511477) to NORGE-4 (511483) 138kV line CKT 1, near S.W.S-4. a. Apply fault at the S.W.S-4 138 kV bus. b. Clear fault after 7 cycles by tripping the faulted line. c. Wait 20 cycles, and then re-close the line in (b) back into the fault. d. Leave fault on for 7 cycles, then trip the line in (b) and remove fault.
FLT9032-3PH	P1	3 phase fault on the S.W.S-4 (511477) to G16-097-TAP (587794) 138kV line CKT 1, near S.W.S-4. a. Apply fault at the S.W.S-4 138 kV bus. b. Clear fault after 7 cycles by tripping the faulted line. c. Wait 20 cycles, and then re-close the line in (b) back into the fault. d. Leave fault on for 7 cycles, then trip the line in (b) and remove fault.
FLT9033-3PH	P1	3 phase fault on the GEROGIA4 (520923) to FLETCH-4 (520912) 138kV line CKT 1, near GEROGIA4. a. Apply fault at the GEROGIA4 138 kV bus. b. Clear fault after 7 cycles by tripping the faulted line. c. Wait 20 cycles, and then re-close the line in (b) back into the fault. d. Leave fault on for 7 cycles, then trip the line in (b) and remove fault.
FLT9034-3PH	P1	3 phase fault on the SEQUOYAHJ4 (520422) to SEQOYAH4 (520547) 138kV line CKT 1, near SEQUOYAHJ4. a. Apply fault at the SEQUOYAHJ4 138 kV bus. b. Clear fault after 7 cycles by tripping the faulted line. c. Wait 20 cycles, and then re-close the line in (b) back into the fault. d. Leave fault on for 7 cycles, then trip the line in (b) and remove fault.
FLT9035-3PH	P1	3 phase fault on the SEQUOYAHJ4 (520422) to CKSHATP4 (520473) 138kV line CKT 1, near SEQUOYAHJ4. a. Apply fault at the SEQUOYAHJ4 138 kV bus. b. Clear fault after 7 cycles by tripping the faulted line. c. Wait 20 cycles, and then re-close the line in (b) back into the fault. d. Leave fault on for 7 cycles, then trip the line in (b) and remove fault.
FLT9036-3PH	P1	3 phase fault on the WASHITA 138 kV (521089) /69 kV (521088) /7.2kV (521179) transformer CKT 1, near WASHITA4 138kV. a. Apply fault at the WASHITA4 138 kV (521089) bus. b. Clear fault after 7 cycles by tripping the faulted line.
FLT9037-3PH	P1	3 phase fault on the WASHITA4 (521089) to ONEY 4 (521017) 138kV line CKT 1, near WASHITA4. a. Apply fault at the WASHITA4 138 kV bus. b. Clear fault after 7 cycles by tripping the faulted line. c. Wait 20 cycles, and then re-close the line in (b) back into the fault. d. Leave fault on for 7 cycles, then trip the line in (b) and remove fault.
FLT9038-3PH	P1	3 phase fault on the WASHITA4 (521089) to SLKHILLS 4 (521103) 138kV line CKT 1, near WASHITA4. a. Apply fault at the WASHITA4 138 kV bus. b. Clear fault after 7 cycles by tripping the faulted line. Trip generator on bus BCVI_WTG1 (520522), BCI_WTG (520519), BLUCAN2-WTG1 (920001), BLUCAN2-WTG2 (920002), BLUCAN2-WTG3 (920003), BLUCAN2-WTG4 (920004), BLUCAN2-WTG5 (599003) c. Wait 20 cycles, and then re-close the line in (b) back into the fault. d. Leave fault on for 7 cycles, then trip the line in (b) and remove fault.
FLT9039-3PH	P1	3 phase fault on the ELSWORTH 4 (511563) to ELGINJT4 (511486) 138kV line CKT 1, near ELSWORTH 4. a. Apply fault at the ELSWORTH 4 138 kV bus. b. Clear fault after 7 cycles by tripping the faulted line. c. Wait 20 cycles, and then re-close the line in (b) back into the fault. d. Leave fault on for 7 cycles, then trip the line in (b) and remove fault.
FLT9040-3PH	P1	3 phase fault on the CARNEG-4 (511445) to HOB-JCT4 (511463) 138kV line CKT 1, near CARNEG-4. a. Apply fault at the CARNEG-4 138 kV bus. b. Clear fault after 7 cycles by tripping the faulted line. c. Wait 20 cycles, and then re-close the line in (b) back into the fault. d. Leave fault on for 7 cycles, then trip the line in (b) and remove fault.

**Table 5 Continued**

Fault ID	Planning Event	Fault Descriptions
FLT9041-3PH	P1	3 phase fault on the VERDEN 4 (511421) to N29CHIK4 (511502) 138kV line CKT 1, near VERDEN 4. a. Apply fault at the VERDEN 4 138 kV bus. b. Clear fault after 7 cycles by tripping the faulted line. c. Wait 20 cycles, and then re-close the line in (b) back into the fault. d. Leave fault on for 7 cycles, then trip the line in (b) and remove fault.
FLT9042-3PH	P1	3 phase fault on the NORGE-4 (511483) to CORNVIL4 (511449) 138kV line CKT 1, near NORGE-4. a. Apply fault at the NORGE-4 138 kV bus. b. Clear fault after 7 cycles by tripping the faulted line. c. Wait 20 cycles, and then re-close the line in (b) back into the fault. d. Leave fault on for 7 cycles, then trip the line in (b) and remove fault.
FLT9043-3PH	P1	3 phase fault on the G16-097-TAP (587794) to FLE TAP4 (511423) 138kV line CKT 1, near G16-097-TAP. a. Apply fault at the G16-097-TAP 138 kV bus. b. Clear fault after 7 cycles by tripping the faulted line. c. Wait 20 cycles, and then re-close the line in (b) back into the fault. d. Leave fault on for 7 cycles, then trip the line in (b) and remove fault.
FLT9044-3PH	P1	3 phase fault on the FLETCH-4 (520912) to EMPIRE 4 (520900) 138kV line CKT 1, near FLETCH-4. a. Apply fault at the FLETCH-4 138 kV bus. b. Clear fault after 7 cycles by tripping the faulted line. c. Wait 20 cycles, and then re-close the line in (b) back into the fault. d. Leave fault on for 7 cycles, then trip the line in (b) and remove fault.
FLT9045-3PH	P1	3 phase fault on the FLETCH 138 kV (520912) /69 kV (520911) /13.8kV (521168) transformer CKT 1, near FLETCH-4 138kV. a. Apply fault at the FLETCH-4 138 kV (520912) bus. b. Clear fault after 7 cycles by tripping the faulted line.
FLT9046-3PH	P1	3 phase fault on the CKSHATP4 (520473) to CORN TP4 (520867) 138kV line CKT 1, near CKSHATP4. a. Apply fault at the CKSHATP4 138 kV bus. b. Clear fault after 7 cycles by tripping the faulted line. c. Wait 20 cycles, and then re-close the line in (b) back into the fault. d. Leave fault on for 7 cycles, then trip the line in (b) and remove fault.
FLT9047-3PH	P1	3 phase fault on the CKSHATP4 (520473) to CHCKSHA4 (520472) 138kV line CKT 1, near CKSHATP4. a. Apply fault at the CKSHATP4 138 kV bus. b. Clear fault after 7 cycles by tripping the faulted line. c. Wait 20 cycles, and then re-close the line in (b) back into the fault. d. Leave fault on for 7 cycles, then trip the line in (b) and remove fault.
FLT9048-3PH	P1	3 phase fault on the GRACMNT4 (515800) to MINCO 7 (514801) 345kV line CKT 1, near GRACMNT4. a. Apply fault at the GRACMNT4 345 kV bus. b. Clear fault after 6 cycles by tripping the faulted line. c. Wait 20 cycles, and then re-close the line in (b) back into the fault. d. Leave fault on for 6 cycles, then trip the line in (b) and remove fault.
FLT9049-3PH	P1	3 phase fault on the GRACMNT4 (515800) to GEN-2015-093 (563269) 345kV line CKT 1, near GRACMNT4. a. Apply fault at the GRACMNT4 345 kV bus. b. Clear fault after 6 cycles by tripping the faulted line. Trip generator on bus G15-093-GEN1 (563272), G15-093-GEN2 (563273) c. Wait 20 cycles, and then re-close the line in (b) back into the fault. d. Leave fault on for 6 cycles, then trip the line in (b) and remove fault.
FLT9050-3PH	P1	3 phase fault on the GRACMNT4 (515800) to G16-091-TAP (587744) 345kV line CKT 1, near GRACMNT4. a. Apply fault at the GRACMNT4 345 kV bus. b. Clear fault after 6 cycles by tripping the faulted line. Trip generator on bus G16-095-GEN1 (587773), G16-091-GEN3 (587747), G16-091-GEN4 (587748), G16-091-GEN1 (587743), G16-091-GEN2 (587749) c. Wait 20 cycles, and then re-close the line in (b) back into the fault. d. Leave fault on for 6 cycles, then trip the line in (b) and remove fault.
FLT9051-3PH	P1	3 phase fault on the GRACMNT4 (515800) to G16-037-TAP (560078) 345kV line CKT 1, near GRACMNT4. a. Apply fault at the GRACMNT4 345 kV bus. b. Clear fault after 6 cycles by tripping the faulted line. c. Wait 20 cycles, and then re-close the line in (b) back into the fault. d. Leave fault on for 6 cycles, then trip the line in (b) and remove fault.



**Table 5 Continued**

Fault ID	Planning Event	Fault Descriptions
FLT9052-3PH	P1	3 phase fault on the MINCO 7 (514801) to MCNOWND7 (515444) 345kV line CKT 1, near MINCO 7. a. Apply fault at the MINCO 7 345 kV bus. b. Clear fault after 6 cycles by tripping the faulted line. Trip generator on bus MNCOWNG1 (515907), MNCOWNG3 (515439), MNCOWNG2 (515445) c. Wait 20 cycles, and then re-close the line in (b) back into the fault. d. Leave fault on for 6 cycles, then trip the line in (b) and remove fault.
FLT9053-3PH	P1	3 phase fault on the MINCO 7 (514801) to NSUB345 (555234) 345kV line CKT 1, near MINCO 7. a. Apply fault at the MINCO 7 345 kV bus. b. Clear fault after 6 cycles by tripping the faulted line. c. Wait 20 cycles, and then re-close the line in (b) back into the fault. d. Leave fault on for 6 cycles, then trip the line in (b) and remove fault.
FLT9054-3PH	P1	3 phase fault on the MINCO 7 (514801) to CIMARON7 (514901) 345kV line CKT 1, near MINCO 7. a. Apply fault at the MINCO 7 345 kV bus. b. Clear fault after 6 cycles by tripping the faulted line. c. Wait 20 cycles, and then re-close the line in (b) back into the fault. d. Leave fault on for 6 cycles, then trip the line in (b) and remove fault.
FLT9055-3PH	P1	3 phase fault on the MINCO 7 (514801) to GEN-2017-233 (761250) 345kV line CKT 1, near MINCO 7. a. Apply fault at the MINCO 7 345 kV bus. b. Clear fault after 6 cycles by tripping the faulted line. Trip generator on bus G17-233-GEN1 (761253), G17-150GEN1 (761232) c. Wait 20 cycles, and then re-close the line in (b) back into the fault. d. Leave fault on for 6 cycles, then trip the line in (b) and remove fault.
FLT9056-3PH		3 phase fault on the MINCO 7 (514801) to MNCWWD37 (515549) 345kV line CKT 1, near MINCO 7. a. Apply fault at the MINCO 7 345 kV bus. b. Clear fault after 6 cycles by tripping the faulted line. Trip generator on bus MINCO-WTG34 (599120), MINCO-WTG32 (515551), MINCO-WTG33 (599119), MINCO-WTG31 (599117), MNCO4G11 (515967), MNCO4G21 (515968), MNCO4G31 (515969), MNCO5G11 (515984), MNCO5G31 (515986), MNCO5G21 (515985) c. Wait 20 cycles, and then re-close the line in (b) back into the fault. d. Leave fault on for 6 cycles, then trip the line in (b) and remove fault.
FLT9057-3PH	P1	3 phase fault on the G16-091-TAP (587744) to GEN-2016-095 (587770) 345kV line CKT 1, near G16-091-TAP. a. Apply fault at the G16-091-TAP 345 kV bus. b. Clear fault after 6 cycles by tripping the faulted line. Trip generator on bus G16-095-GEN1 (587773) c. Wait 20 cycles, and then re-close the line in (b) back into the fault. d. Leave fault on for 6 cycles, then trip the line in (b) and remove fault.
FLT9058-3PH	P1	3 phase fault on the G16-091-TAP (587744) to GEN-2016-091 (587740) 345kV line CKT 1, near G16-091-TAP. a. Apply fault at the G16-091-TAP 345 kV bus. b. Clear fault after 6 cycles by tripping the faulted line. Trip generator on bus G16-091-GEN3 (587747), G16-091-GEN4 (587748), G16-091-GEN1 (587743), G16-091-GEN2 (587749) c. Wait 20 cycles, and then re-close the line in (b) back into the fault. d. Leave fault on for 6 cycles, then trip the line in (b) and remove fault.
FLT9059-3PH	P1	3 phase fault on the G16-091-TAP (587744) to L.E.S.-7 (511468) 345kV line CKT 1, near G16-091-TAP. a. Apply fault at the G16-091-TAP 345 kV bus. b. Clear fault after 6 cycles by tripping the faulted line. Trip generator on bus G18-115-GSU4 (763328), G18-115-GSU1 (763320) c. Wait 20 cycles, and then re-close the line in (b) back into the fault. d. Leave fault on for 6 cycles, then trip the line in (b) and remove fault.
FLT9060-3PH	P1	3 phase fault on the G16-037-TAP (560078) to GEN-2016-037 (587230) 345kV line CKT 1, near G16-037-TAP. a. Apply fault at the G16-037-TAP 345 kV bus. b. Clear fault after 6 cycles by tripping the faulted line. Trip generator on bus G16-037-GEN1 (587235), G16-037-GEN3 (587236), G18-021GEN1 (762573) c. Wait 20 cycles, and then re-close the line in (b) back into the fault. d. Leave fault on for 6 cycles, then trip the line in (b) and remove fault.



**Table 5 Continued**

Fault ID	Planning Event	Fault Descriptions
FLT9061-3PH	P1	3 phase fault on the G16-037-TAP (560078) to CHISHOLM7 (511553) 345kV line CKT 1, near G16-037-TAP. a. Apply fault at the G16-037-TAP 345 kV bus. b. Clear fault after 6 cycles by tripping the faulted line. c. Wait 20 cycles, and then re-close the line in (b) back into the fault. d. Leave fault on for 6 cycles, then trip the line in (b) and remove fault.
FLT9062-3PH	P1	3 phase fault on the NSUB345 (555234) to CIMARON7 (514901) 345kV line CKT 1, near NSUB345. a. Apply fault at the NSUB345 345 kV bus. b. Clear fault after 6 cycles by tripping the faulted line. c. Wait 20 cycles, and then re-close the line in (b) back into the fault. d. Leave fault on for 6 cycles, then trip the line in (b) and remove fault.
FLT1001-SB	P4	<b>Stuck Breaker on at GRACMNT4 (515802) at 138kV</b> a. Apply single-phase fault at GRACMNT4 (515802) on the 138kV bus. b. Clear fault after 16 cycles and remove fault. c. Trip the GRACMNT4 (515802) to WASHITA4 (521089) 138kV line CKT 1. d. Trip the GRACMNT3 138 kV (515802) /345 kV (515800) /13.8kV (515801) transformer CKT 1.
FLT1002-SB	P4	<b>Stuck Breaker on at GRACMNT4 (515802) at 138kV</b> a. Apply single-phase fault at GRACMNT4 (515802) on the 138kV bus. b. Clear fault after 16 cycles and remove fault. c. Trip the GRACMNT3 (515802) to ANADARK4 (520814) 138kV line CKT 1. Trip the GRACMNT3 (515802) to ANADARK4 (520814) 138kV line CKT 2. d. Trip the GRACMNT3 138 kV (515802) /345 kV (515800) /13.8kV (515801) transformer CKT 1.
FLT1003-SB	P4	<b>Stuck Breaker on at GRACMNT4 (515802) at 138kV</b> a. Apply single-phase fault at GRACMNT4 (515802) on the 138kV bus. b. Clear fault after 16 cycles and remove fault. c. Trip the GRACMNT3 (515802) to ANADARK4 (520814) 138kV line CKT 1. Trip the GRACMNT3 (515802) to ANADARK4 (520814) 138kV line CKT 2. d. Trip the GRACMNT4 (515802) to WASHITA4 (521089) 138kV line CKT 2.
FLT1004-SB	P4	<b>Stuck Breaker on at GRACMNT4 (515802) at 138kV</b> a. Apply single-phase fault at GRACMNT4 (515802) on the 138kV bus. b. Clear fault after 16 cycles and remove fault. c. Trip the GRACMNT4 (515802) to WASHITA4 (521089) 138kV line CKT 1. d. Trip the GRACMNT4 (515802) to WASHITA4 (521089) 138kV line CKT 2.
FLT1005-SB	P4	<b>Stuck Breaker on at GRACMNT7 (515800) at 345kV</b> a. Apply single-phase fault at GRACMNT7 (515800) on the 345kV bus. b. Clear fault after 16 cycles and remove fault. c. Trip the GRACMNT7 (515800) to MINCO (514801) 345kV line CKT 1. d. Trip the GRACMNT7 (515800) to G16-091-TAP (587744) 345kV line CKT 1.
FLT1006-SB	P4	<b>Stuck Breaker on at GRACMNT7 (515800) at 345kV</b> a. Apply single-phase fault at GRACMNT7 (515800) on the 345kV bus. b. Clear fault after 16 cycles and remove fault. c. Trip the GRACMNT3 138 kV (515802) /345 kV (515800) /13.8kV (515801) transformer CKT 1. d. Trip the GRACMNT7 (515800) to G16-091-TAP (587744) 345kV line CKT 1.
FLT1007-SB	P4	<b>Stuck Breaker on at GRACMNT7 (515800) at 345kV</b> a. Apply single-phase fault at GRACMNT7 (515800) on the 345kV bus. b. Clear fault after 16 cycles and remove fault. c. Trip the GRACMNT7 (515800) to G16-037-TAP (560078) 345kV line CKT 1. d. Trip the GRACMNT3 138 kV (515802) /345 kV (515800) /13.8kV (515801) transformer CKT 1.
FLT1008-SB	P4	<b>Stuck Breaker on at GRACMNT7 (515800) at 345kV</b> a. Apply single-phase fault at GRACMNT7 (515800) on the 345kV bus. b. Clear fault after 16 cycles and remove fault. c. Trip the GRACMNT7 (515800) to MINCO (514801) 345kV line CKT 1. d. Trip the GRACMNT7 (515800) to G16-037-TAP (560078) 345kV line CKT 1.
FLT1009-SB	P4	<b>Stuck Breaker on at S.W.S.-4 (511477) at 138kV</b> a. Apply single-phase fault at S.W.S.-4 (511477) on the 138kV bus. b. Clear fault after 16 cycles and remove fault. c. Trip the S.W.S.-4 (511477) to NORGE-4 (511483) 138kV line CKT 1. d. Trip the S.W.S.-4 138 kV (511477) /69 kV (511476) /13.8kV (511413) transformer CKT 1.

**Table 5 Continued**

Fault ID	Planning Event	Fault Descriptions
FLT1010-SB	P4	<p><b>Stuck Breaker on at S.W.S.-4 (511477) at 138kV</b></p> <p>a. Apply single-phase fault at S.W.S.-4 (511477) on the 138kV bus.                      b. Clear fault after 16 cycles and remove fault.                      c. Trip the S.W.S.-4 (511477) to WASHITA4 (521089) 138kV line CKT 1.                      d. Trip S.W.S.-4 138 kV (511477) /13.8 kV (511849) /13.8kV (511850) transformer CKT 1.                      Trip generator SWS NG4 (511849).                      Trip generator SWS NG5 (511850).</p>
FLT1011-SB	P4	<p><b>Stuck Breaker on at S.W.S.-4 (511477) at 138kV</b></p> <p>a. Apply single-phase fault at S.W.S.-4 (511477) on the 138kV bus.                      b. Clear fault after 16 cycles and remove fault.                      c. Trip the S.W.S.-4 (511477) to ANADARK4 (520814) 138kV line CKT 1.                      d. Trip the S.W.S.-4 (511477) to VERDEN 4 (511421) 138kV line CKT 1.</p>
FLT1012-SB	P4	<p><b>Stuck Breaker on at S.W.S.-4 (511477) at 138kV</b></p> <p>a. Apply single-phase fault at S.W.S.-4 (511477) on the 138kV bus.                      b. Clear fault after 16 cycles and remove fault.                      c. Trip the S.W.S.-4 (511477) to CARNEG-4 4 (511445) 138kV line CKT 1.                      d. Trip S.W.S 138/24kV (511477 /511848) transformer CKT 1.                      Trip generator SWS3-1 (511848).</p>
FLT1013-SB	P4	<p><b>Stuck Breaker on at S.W.S.-4 (511477) at 138kV</b></p> <p>a. Apply single-phase fault at S.W.S.-4 (511477) on the 138kV bus.                      b. Clear fault after 16 cycles and remove fault.                      c. Trip the S.W.S.-4 (511477) to G16-097-TAP (587794) 138kV line CKT 1.                      d. Trip S.W.S 138/14.4kV (511477 /511846) transformer CKT 1.                      Trip generator SWS1-1 (511846).</p>
FLT1014-SB	P4	<p><b>Stuck Breaker on at S.W.S.-4 (511477) at 138kV</b></p> <p>a. Apply single-phase fault at S.W.S.-4 (511477) on the 138kV bus.                      b. Clear fault after 16 cycles and remove fault.                      c. Trip the S.W.S.-4 (511477) to ELSWORTH 4 (511563) 138kV line CKT 1.                      d. Trip S.W.S 138/14.4kV (511477 /511847) transformer CKT 1.                      Trip generator SWS2-1 (511847).</p>
FLT1015-SB	P4	<p><b>Stuck Breaker on at ANADARK4 (520814) at 138kV</b></p> <p>a. Apply single-phase fault at ANADARK4 (520814) on the 138kV bus.                      b. Clear fault after 16 cycles and remove fault.                      c. Trip the ANADARK4 (520814) to GRACMNT4 (515802) 138kV line CKT 1.                      d Trip the ANADARK4 (520814) to GRACMNT4 (515802) 138kV line CKT 2.                      e. Trip the ANADARK 138 kV (520814) /13.8 kV (520813) transformer CKT 1.                      Trip generator on bus ANADRK6 (520813)</p>
FLT1016-SB	P4	<p><b>Stuck Breaker on at ANADARK4 (520814) at 138kV</b></p> <p>a. Apply single-phase fault at ANADARK4 (520814) on the 138kV bus.                      b. Clear fault after 16 cycles and remove fault.                      c. Trip the ANADARK4 (520814) to POCASET4 (521031) 138kV line CKT 1.                      d. Trip the ANADARK 138 kV (520814) /13.8 kV (520813) transformer CKT 1.                      Trip generator on bus ANADRK6 (520813)</p>
FLT1017-SB	P4	<p><b>Stuck Breaker on at ANADARK4 (520814) at 138kV</b></p> <p>a. Apply single-phase fault at ANADARK4 (520814) on the 138kV bus.                      b. Clear fault after 16 cycles and remove fault.                      c. Trip the ANADARK4 (520814) to GENCO1 (521101) 138kV line CKT 1.                      d. Trip the ANADARK4 (520814) to GENCO2 (521102) 138kV line CKT 1.                      e. Trip the ANADARK 138 kV (520814) /13.8 kV (520813) transformer CKT 1.                      Trip generator on bus GENCO1 (521101), GENCO2 (521102), ANADRK6 (520813)</p>
FLT1018-SB	P4	<p><b>Stuck Breaker on at ANADARK4 (520814) at 138kV</b></p> <p>a. Apply single-phase fault at ANADARK4 (520814) on the 138kV bus.                      b. Clear fault after 16 cycles and remove fault.                      c. Trip the ORME 138 kV (520814) /13.8 kV (521110) transformer CKT 1.                      d. Trip the ORME 138 kV (520814) /13.8 kV (521111) transformer CKT 1.                      e. Trip the ORME 138 kV (520814) /13.8 kV (521112) transformer CKT 1.                      f. Trip the ANADARK4 (520814) to GENCO1 (521101) 138kV line CKT 1.                      g. Trip the ANADARK4 (520814) to GENCO2 (521102) 138kV line CKT 1.                      Trip generator on bus ORME1 (521110), ORME2 (521111), ORME3 (521112), GENCO1 (521101), GENCO2 (521102)</p>

**Table 5 Continued**

Fault ID	Planning Event	Fault Descriptions
FLT1019-SB	P4	<b>Stuck Breaker on at ANADARK4 (520814) at 138kV</b> a. Apply single-phase fault at ANADARK4 (520814) on the 138kV bus. b. Clear fault after 16 cycles and remove fault. c. Trip the ANADARK4 (520814) to CHERRYRD4 (521129) 138kV line CKT 1. d. Trip the ANADARK4 (520814) to S.W.S-4 (511477) 138kV line CKT 1.
FLT1020-SB	P4	<b>Stuck Breaker on at ANADARK4 (520814) at 138kV</b> a. Apply single-phase fault at ANADARK4 (520814) on the 138kV bus. b. Clear fault after 16 cycles and remove fault. c. Trip the ANADARKO 138 kV (520814) /69 kV (520810) /13.8kV (521181) transformer CKT 1. d. Trip the ANADARK4 (520814) to S.W.S-4 (511477) 138kV line CKT 1.
FLT1021-SB	P4	<b>Stuck Breaker on at ANADARK4 (520814) at 138kV</b> a. Apply single-phase fault at ANADARK4 (520814) on the 138kV bus. b. Clear fault after 16 cycles and remove fault. c. Trip the ANADARKO 138 kV (520814) /69 kV (520810) /13.8kV (521181) transformer CKT 1. d. Trip the ANADARK4 (520814) to GEROGIA4 (520923) 138kV line CKT 1.
FLT1022-SB	P4	<b>Stuck Breaker on at ANADARK4 (520814) at 138kV</b> a. Apply single-phase fault at ANADARK4 (520814) on the 138kV bus. b. Clear fault after 16 cycles and remove fault. c. Trip the ANADARK4 (520814) to SEQUOYAHJ4 (520422) 138kV line CKT 1. d. Trip the ANADARK4 (520814) to GEROGIA4 (520923) 138kV line CKT 1.
FLT1023-SB	P4	<b>Stuck Breaker on at ANADARK4 (520814) at 138kV</b> a. Apply single-phase fault at ANADARK4 (520814) on the 138kV bus. b. Clear fault after 16 cycles and remove fault. c. Trip the ANADARK 138 kV (520814) /13.8 kV (520811) transformer CKT 1. d. Trip the ANADARK 138 kV (520814) /13.8 kV (520812) transformer CKT 1. Trip generator on bus ANADARK4 (520811), ANADARK5 (520812)
FLT1024-SB	P4	<b>Stuck Breaker at CHERRYRD 4 (521129) 138 kV bus</b> a. Apply single phase fault at CHERRYRD 4 bus. b. Clear fault after 16 cycles and trip the following elements c. Trip the Bus CHERRYRD 4 (521129). Trip generator on bus BCV WTG (520521)
FLT1025-SB	P4	<b>Stuck Breaker at POCASET4 (521031) 138 kV bus</b> a. Apply single phase fault at POCASET4 bus. b. Clear fault after 16 cycles and trip the following elements c. Trip the Bus POCASET4 (521031).
FLT1026-SB	P4	<b>Stuck Breaker at CLVLDSW4 (520508) 138 kV bus</b> a. Apply single phase fault at CLVLDSW4 bus. b. Clear fault after 16 cycles and trip the following elements c. Trip the Bus CLVLDSW4 (520508).
FLT1027-SB	P4	<b>Stuck Breaker at GEORGIA4 (520923) 138 kV bus</b> a. Apply single phase fault at GEORGIA4 bus. b. Clear fault after 16 cycles and trip the following elements c. Trip the Bus GEORGIA4 (520923).
FLT1028-SB	P4	<b>Stuck Breaker at SEQUOYAHJ4 (520422) 138 kV bus</b> a. Apply single phase fault at SEQUOYAHJ4 bus. b. Clear fault after 16 cycles and trip the following elements c. Trip the Bus SEQUOYAHJ4 (520422).

## RESULTS

Table 6 shows the relevant results of the fault events simulated for each of the modified cases. Existing DISIS base case issues are documented separately in Appendix C. The associated stability plots are also provided in Appendix C.

**Table 6: Stability Analysis Results**

Fault ID	25SP			25WP		
	Voltage Violation	Voltage Recovery	Stable	Voltage Violation	Voltage Recovery	Stable
FLT9001-3PH	Pass	Pass	Stable	Pass	Pass	Stable
FLT9002-3PH	Pass	Pass	Stable	Pass	Pass	Stable
FLT9003-3PH	Pass	Pass	Stable	Pass	Pass	Stable
FLT9004-3PH	Pass	Pass	Stable	Pass	Pass	Stable
FLT9005-3PH	Pass	Pass	Stable	Pass	Pass	Stable
FLT9006-3PH	Pass	Pass	Stable	Pass	Pass	Stable
FLT9007-3PH	Pass	Pass	Stable	Pass	Pass	Stable
FLT9008-3PH	Pass	Pass	Stable	Pass	Pass	Stable
FLT9009-3PH	Pass	Pass	Stable	Pass	Pass	Stable
FLT9010-3PH	Pass	Pass	Stable	Pass	Pass	Stable
FLT9011-3PH	Pass	Pass	Stable	Pass	Pass	Stable
FLT9012-3PH	Pass	Pass	Stable	Pass	Pass	Stable
FLT9013-3PH	Pass	Pass	Stable	Pass	Pass	Stable
FLT9014-3PH	Pass	Pass	Stable	Pass	Pass	Stable
FLT9015-3PH	Pass	Pass	Stable	Pass	Pass	Stable
FLT9016-3PH	Pass	Pass	Stable	Pass	Pass	Stable
FLT9017-3PH	Pass	Pass	Stable	Pass	Pass	Stable
FLT9018-3PH	Pass	Pass	Stable	Pass	Pass	Stable
FLT9019-3PH	Pass	Pass	Stable	Pass	Pass	Stable
FLT9020-3PH	Pass	Pass	Stable	Pass	Pass	Stable
FLT9021-3PH	Pass	Pass	Stable	Pass	Pass	Stable
FLT9022-3PH	Pass	Pass	Stable	Pass	Pass	Stable
FLT9023-3PH	Pass	Pass	Stable	Pass	Pass	Stable
FLT9024-3PH	Pass	Pass	Stable	Pass	Pass	Stable
FLT9025-3PH	Pass	Pass	Stable	Pass	Pass	Stable
FLT9026-3PH	Pass	Pass	Stable	Pass	Pass	Stable
FLT9027-3PH	Pass	Pass	Stable	Pass	Pass	Stable
FLT9028-3PH	Pass	Pass	Stable	Pass	Pass	Stable
FLT9029-3PH	Pass	Pass	Stable	Pass	Pass	Stable
FLT9030-3PH	Pass	Pass	Stable	Pass	Pass	Stable
FLT9031-3PH	Pass	Pass	Stable	Pass	Pass	Stable
FLT9032-3PH	Pass	Pass	Stable	Pass	Pass	Stable
FLT9033-3PH	Pass	Pass	Stable	Pass	Pass	Stable
FLT9034-3PH	Pass	Pass	Stable	Pass	Pass	Stable
FLT9035-3PH	Pass	Pass	Stable	Pass	Pass	Stable

**Table 6 Continued**

Fault ID	25SP			25WP		
	Voltage Violation	Voltage Recovery	Stable	Voltage Violation	Voltage Recovery	Stable
FLT9036-3PH	Pass	Pass	Stable	Pass	Pass	Stable
FLT9037-3PH	Pass	Pass	Stable	Pass	Pass	Stable
FLT9038-3PH	Pass	Pass	Stable	Pass	Pass	Stable
FLT9039-3PH	Pass	Pass	Stable	Pass	Pass	Stable
FLT9040-3PH	Pass	Pass	Stable	Pass	Pass	Stable
FLT9041-3PH	Pass	Pass	Stable	Pass	Pass	Stable
FLT9042-3PH	Pass	Pass	Stable	Pass	Pass	Stable
FLT9043-3PH	Pass	Pass	Stable	Pass	Pass	Stable
FLT9044-3PH	Pass	Pass	Stable	Pass	Pass	Stable
FLT9045-3PH	Pass	Pass	Stable	Pass	Pass	Stable
FLT9046-3PH	Pass	Pass	Stable	Pass	Pass	Stable
FLT9047-3PH	Pass	Pass	Stable	Pass	Pass	Stable
FLT9048-3PH	Pass	Pass	Stable	Pass	Pass	Stable
FLT9049-3PH	Pass	Pass	Stable	Pass	Pass	Stable
FLT9050-3PH	Pass	Pass	Stable	Pass	Pass	Stable
FLT9051-3PH	Pass	Pass	Stable	Pass	Pass	Stable
FLT9052-3PH	Pass	Pass	Stable	Pass	Pass	Stable
FLT9053-3PH	Pass	Pass	Stable	Pass	Pass	Stable
FLT9054-3PH	Pass	Pass	Stable	Pass	Pass	Stable
FLT9055-3PH	Pass	Pass	Stable	Pass	Pass	Stable
FLT9056-3PH	Pass	Pass	Stable	Pass	Pass	Stable
FLT9057-3PH	Pass	Pass	Stable	Pass	Pass	Stable
FLT9058-3PH	Pass	Pass	Stable	Pass	Pass	Stable
FLT9059-3PH	Pass	Pass	Stable	Pass	Pass	Stable
FLT9060-3PH	Pass	Pass	Stable	Pass	Pass	Stable
FLT9061-3PH	Pass	Pass	Stable	Pass	Pass	Stable
FLT9062-3PH	Pass	Pass	Stable	Pass	Pass	Stable
FLT1001-SB	Pass	Pass	Stable	Pass	Pass	Stable
FLT1002-SB	Pass	Pass	Stable	Pass	Pass	Stable
FLT1003-SB	Pass	Pass	Stable	Pass	Pass	Stable
FLT1004-SB	Pass	Pass	Stable	Pass	Pass	Stable
FLT1005-SB	Pass	Pass	Stable	Pass	Pass	Stable
FLT1006-SB	Pass	Pass	Stable	Pass	Pass	Stable
FLT1007-SB	Pass	Pass	Stable	Pass	Pass	Stable

**Table 6 Continued**

Fault ID	25SP			25WP		
	Voltage Violation	Voltage Recovery	Stable	Voltage Violation	Voltage Recovery	Stable
FLT1008-SB	Pass	Pass	Stable	Pass	Pass	Stable
FLT1009-SB	Pass	Pass	Stable	Pass	Pass	Stable
FLT1010-SB	Pass	Pass	Stable	Pass	Pass	Stable
FLT1011-SB	Pass	Pass	Stable	Pass	Pass	Stable
FLT1012-SB	Pass	Pass	Stable	Pass	Pass	Stable
FLT1013-SB	Pass	Pass	Stable	Pass	Pass	Stable
FLT1014-SB	Pass	Pass	Stable	Pass	Pass	Stable
FLT1015-SB	Pass	Pass	Stable	Pass	Pass	Stable
FLT1016-SB	Pass	Pass	Stable	Pass	Pass	Stable
FLT1017-SB	Pass	Pass	Stable	Pass	Pass	Stable
FLT1018-SB	Pass	Pass	Stable	Pass	Pass	Stable
FLT1019-SB	Pass	Pass	Stable	Pass	Pass	Stable
FLT1020-SB	Pass	Pass	Stable	Pass	Pass	Stable
FLT1021-SB	Pass	Pass	Stable	Pass	Pass	Stable
FLT1022-SB	Pass	Pass	Stable	Pass	Pass	Stable
FLT1023-SB	Pass	Pass	Stable	Pass	Pass	Stable
FLT1024-SB	Pass	Pass	Stable	Pass	Pass	Stable
FLT1025-SB	Pass	Pass	Stable	Pass	Pass	Stable
FLT1026-SB	Pass	Pass	Stable	Pass	Pass	Stable
FLT1027-SB	Pass	Pass	Stable	Pass	Pass	Stable
FLT1028-SB	Pass	Pass	Stable	Pass	Pass	Stable

The results of the dynamic stability analysis showed several existing base case issues that were found in both the original DISIS-2018-002/2019-001 model and the model with GEN-2023-GR1 included. These issues were not attributed to the GEN-2023-GR1 replacement request and are detailed in Appendix C.

There were no damping or voltage recovery violations attributed to the GEN-2023-GR1 replacement request observed during the simulated faults.

## INSTALLED CAPACITY EXCEEDS GIA CAPACITY

Under FERC Order 845, Interconnection Customers are allowed to request Interconnection Service that is lower than the full generating capacity of their planned generating facilities. The Interconnection Customers must install acceptable control and protection devices that prevent the injection above their requested Interconnection Service amount measured at the POI.

## NECESSARY INTERCONNECTION FACILITIES

This study identified necessary Interconnection Facilities to accommodate GEN-2023-GR1 as shown in Table 7.

**Table 7: Necessary Interconnection Facilities**

Upgrade Name	Upgrade Description
Anadarko 69 kV GEN-2023-GR1 Interconnection (TOIF) (WFEC)	Interconnection upgrades and cost estimates needed to interconnect the following Interconnection Customer facility, GEN-2023-GR1, into the POI at Anadarko 69 kV.
Anadarko 69 kV GEN-2023-GR1 Interconnection (Non-Shared NU) (WFEC)	Interconnection upgrades and cost estimates needed to interconnect the following Interconnection Customer facility, GEN-2023-GR1, into the POI at Anadarko 69 kV.

Should the Interconnection Customer choose to move forward with this request, an Interconnection Facilities Study will be necessary to determine the full scope, cost, and time required to interconnect these upgrades. SPP will work with the TO(s) indicated for the Interconnection Facilities Study.

# RESULTS

---

## RELIABILITY ASSESSMENT STUDY

Because the EGF was considered retired prior to the Generating Facility Replacement, the performance of the Transmission System with the EGF ceasing commercial operations is the status quo. SPP determined that for the Reliability Assessment Study, no further analysis for the time between removing from service of the EGF and the commission of the RGF is necessary, and no mitigations are applicable.

## REPLACEMENT IMPACT STUDY

In accordance with SPP tariff Attachment V, any material adverse impact from operating the RGF when compared to the EGF would be identified as a Material Modification. In the case that the Interconnection Customer chooses to move forward with the RGF, it must submit the RGF as a new Interconnection Request.

Because no material adverse impacts to the SPP Transmission System were identified, SPP determined the requested replacement is **not a Material Modification**. SPP determined that the requested replacement did not cause a materially adverse impact to the dynamic stability and short-circuit characteristics of the SPP system.

This determination implies that no new upgrades beyond those required for interconnection of the RGF are required, thus not resulting in a material adverse impact on the cost or timing of any other Interconnection Request with a later Queue priority date.

## NEXT STEPS

As the requested replacement is determined to not be a Material Modification, pursuant to SPP tariff Attachment V section 3.9.3, the Interconnection Customer shall inform SPP within 30 Calendar Days after having received these study results of its election to proceed.

If the Interconnection Customer chooses to proceed with the studied replacement, SPP will initiate an Interconnection Facilities Study and subsequently tender a draft GIA. The Interconnection Customer shall withdraw any associated Attachment AB retirement requests of the EGF, if applicable, and complete the Attachment AE requirements for de-registration of the EGF and registration of the RGF, including transfer or termination of applicable existing transmission service. If the Interconnection Customer would like to obtain new deliverability to final customers, a separate request for transmission service must be requested on SPP's OASIS.



Failure by the Interconnection Customer to provide an election to proceed within 30 Calendar Days will result in withdrawal of the Interconnection Request pursuant to section 3.7 of SPP tariff Attachment V.